

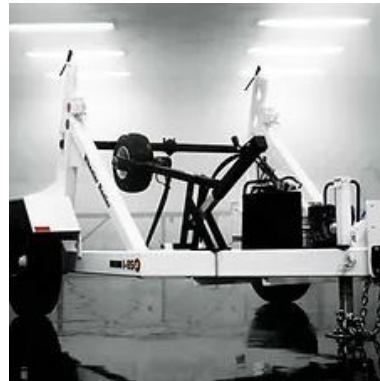

No CDL Required

None of our single reel trailers exceed a GVWR of 10,000 lb thanks to smart engineering. This gives companies added flexibility for transporting.



Removeable Winder

Secured by a heavy duty pin and U bolt. Our winder unlike others is easily removable which allows crews added flexibility without sacrificing power.



Auto Latching Safety Feature

Keep the safety bar firmly locked to prevent injury of operators. Squeeze to unlock.

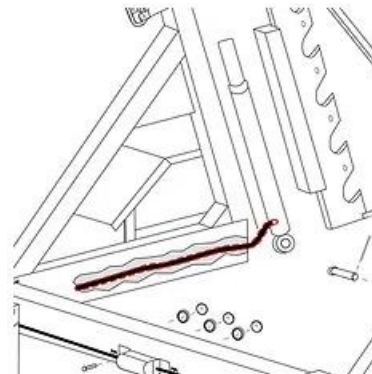

Protected Hydraulic Hoses & Wiring

Hydraulic hoses, brake & lighting wires are tucked inside the trailer frame for increased reliability and less down time due to wear.



LED Lights

LED lights give operators increased visibility & safety in low light environments.



Fully Hydraulic Self Loading

We offer manual hand pumps or electrical pumps to fit your fleet needs. This makes for easy 1 operator loading & unloading.



Uneven Terrain

Simply pull one transport lock pin & let the desired side lower via the hydraulic system. This allows for safer operation in tough terrain.



Electrical Connector Customization

We offer several different electrical connectors to match the rest of your fleet.



Easy on the Wallet

Our trailers are priced very competitively. On the back end thanks to our renowned build quality in the telecommunications, electrical & irrigation industries our trailers resale for higher than others.



Hitch Options

Hitch options that fit your existing fleet.